

Published in:  
"Low Temperature and Cryogenic Refrigeration",  
edited by S. Kakac, H. Smirnov, and M.R. Avelino,  
Kluwer Academic Publishers, Dordrecht, The  
Netherlands (2003), pp. 415-434.

## **PULSE TUBE CRYOCOOLERS\***

RAY RADEBAUGH  
Physical and Chemical Properties Division  
National Institute of Standards and Technology  
Boulder, Colorado 80303, USA

### **1. Introduction**

This paper presents a review of the pulse tube refrigerator from its inception in the mid-1960s up to the present. Various factors are discussed which brought it from a laboratory curiosity to the point where it is now the most efficient of all cryocoolers (cryogenic refrigerator) for temperatures between about 60 and 120 K, and it is reliable enough to be used on space missions. Efficiencies as high as 24% of Carnot at 80 K and temperatures as low as 2 K have been achieved in pulse tube refrigerators. The operating principles for the different types of pulse tube and thermoacoustic refrigerators are described. Pulse tube refrigerators operate with oscillating pressures and mass flows and have no moving parts in the cold end. For large industrial systems the mechanical compressor can be replaced with one of two types of thermoacoustic drivers to yield a refrigerator with no moving parts. Recent advances in understanding and reducing losses in various components are described that have led to the improved efficiencies. A brief description is also given of other types of cryocoolers to aid in a comparison of the pulse tube cryocooler with other types of cryocoolers. The major problems associated with cryocoolers are listed, and it is shown that pulse tube refrigerators have begun to overcome many of these problems. As a result, they are now being used or considered for many different applications. Some of these applications as well as example pulse tube refrigerators are described.

The vapor-compression refrigerator, first developed in the latter part of the 19th century, has provided most of the world's refrigeration needs during the 20th century. In a single stage it can produce temperatures down to about 230 K (-43 °C), provided the appropriate refrigerant is used. Since the middle of the 20th century a steadily increasing demand for cryogenic temperatures (<120 K) has developed for a wide variety of applications. Initially most of these applications were for the liquefaction of air and natural gas, for which very large plants have been developed. Power inputs of many megawatts are typical for these systems. More recently a need for small cryogenic refrigerators (cryocoolers) has evolved for a variety of applications. The requirements imposed in each of these applications have been difficult to meet and have been the impetus for considerable research and development in the field of cryocoolers for the past 40 years or so.

Table 1 lists the main problems associated with cryocoolers that have hampered the advancement of many applications. For example, superconductivity would be in more widespread use now if it were not for the problems associated with the cryocoolers needed to cool the superconductors. One such cryocooler, the pulse tube refrigerator, first conceived in the mid-1960s, was of academic interest until the mid-1980s. Since then, improvements in its efficiency have occurred rapidly. Unlike the Stirling or Gifford-McMahon refrigerators, it has no moving parts at the cold end. One variation has also been developed with no moving parts in the entire system. It uses heat input at one end to power a thermoacoustic driver in place of a mechanical driver that uses electrical input to the motor. The lack of cold moving parts in all types of pulse tube cryocoolers has allowed it to solve some of the problems associated with cryocoolers in many different applications, such as vibration and reliability. Initially its operating principles were quite mysterious. Conventional thermodynamics, used for over a century to explain steady-flow systems, such as the vapor-compression refrigerator, required extensions into the realm of oscillating thermodynamics or thermoacoustics to explain the oscillating flow processes involved in the pulse tube

---

\* Contribution of NIST, not subject to copyright in the U. S.

TABLE 1. Cryocooler problems

- Reliability
- Efficiency
- Size and weight
- Vibration
- Electromagnetic Interference (EMI)
- Heat rejection
- Cost

refrigerator. As its principles became better understood, modifications and improved designs yielded much improved efficiencies. It has now become the most efficient cryocooler for a given size and for temperatures in the range of about 60 to 120 K, and it is planned for use in cooling infrared focal-plane arrays in many space missions. These improvements, funded in large part by NASA and the military, have led to significant commercial spin-offs in the sense that this new technology is being considered for many commercial applications.

This review of pulse tube refrigerators introduces the different types of pulse tube refrigerators and discusses their operating principles. The important factors are discussed that have brought the orifice pulse tube refrigerator to its current position as one of the most promising cryocoolers for a wide variety of applications. Previous reviews of pulse tube refrigerators were given in 1986 [1] and 1990 [2] by the author. In 1997 [3] the author reviewed advances made in the last 10 years in all types of cryocoolers. The review here focuses primarily on pulse tube refrigerators, but other types of cryocoolers are discussed briefly to allow for comparisons.

## 2. Applications and Cryocooler Requirements

Table 2 lists the major applications of cryocoolers that are currently in use or have some potential for large impacts. For many years the largest application for cryocoolers was for use by the military in cooling infrared sensors to about 80 K for tactical applications in tanks, airplanes, and missiles. Since about 1950 over 140,000 cryocoolers have been manufactured in the U. S. alone for this application. Refrigeration powers range from about 0.15 W to about 2 W. Stirling cryocoolers, used primarily for this application in the last twenty years, have been able to meet the requirements reasonably well. However, their mean-time-to-failure (MTTF) of about 4000 hours (0.5 years) is far short of the required 5 to 10 year lifetime needed for satellite applications or even the 3 to 5 year lifetime required for most commercial applications. The rapid growth of research and development on pulse tube refrigerators in the last ten years has occurred because of its potential for improved reliability, lower vibration, and lower cost. This research and development has also led to very high efficiencies.

In the past ten years the largest commercial application of cryocoolers has been for cryopumps (about 20,000/year) for the semiconductor fabrication industry. These cryopumps require a few watts of refrigeration at a temperature of about 15 K to cool a charcoal adsorbent bed and a few tens of watts at about 80 K to cryopump mostly water vapor. A two-stage Gifford-McMahon (GM) refrigerator has been used for nearly all of these cryopumps. In the past few years the vibration of the moving displacer in the GM refrigerator has become a problem in semiconductor fabrication as the circuit linewidths become narrower. Two-stage pulse tube refrigerators are now being studied in several laboratories for this application. Two-stage pulse tube refrigerators are capable of reaching temperatures down to about 2 K [4].

The largest pulse tube refrigerators are being developed for the liquefaction of natural gas for clean-burning fuel in fleet vehicles and for liquefaction of the methane-rich gas emitted from landfills of large cities. The world's largest pulse tube refrigerator produces about 2 kW of refrigeration power at 120 K and is being used for the liquefaction of natural gas at a rate of about 500 L/day [5]. Plans are underway to increase the liquefaction rate to about 2000 L/day. These large pulse tube refrigerators use a type of driver with no moving parts, to be described later, that is powered by heat input from burning a portion of the natural gas. The 2000 L/day liquefier is projected to burn about one-third of the incoming natural gas and liquefy the remainder. Because there are no moving parts in the system, reliability is expected to be high and cost is expected to be low.

Table 2. Applications of cryocoolers

<ul style="list-style-type: none"><li>• <b>Military</b><ol style="list-style-type: none"><li>1. Infrared sensors for missile guidance and night vision</li><li>2. Infrared sensors for surveillance (satellite based)</li></ol></li><li>• <b>Police and Security</b><ol style="list-style-type: none"><li>1. Infrared sensors for night vision and rescue</li></ol></li><li>• <b>Environmental</b><ol style="list-style-type: none"><li>1. Infrared sensors for atmospheric studies of ozone hole and greenhouse effects</li><li>2. Infrared sensors for pollution monitoring</li></ol></li><li>• <b>Commercial</b><ol style="list-style-type: none"><li>1. Cryopumps for semiconductor fabrication</li><li>2. High temperature superconductors for cellular-phone base stations</li><li>3. Superconductors for voltage standards</li><li>4. Semiconductors for high-speed computers</li><li>5. Infrared and SQUID sensors for NDE and process monitoring</li></ol></li><li>• <b>Medical</b><ol style="list-style-type: none"><li>1. Cooling superconducting magnets for MRI systems</li><li>2. SQUID magnetometers for heart and brain studies</li><li>3. Liquefaction of oxygen for storage at hospitals and home use</li><li>4. Cryogenic catheters and cryosurgery</li></ol></li><li>• <b>Transportation</b><ol style="list-style-type: none"><li>1. LNG for fleet vehicles</li><li>2. Superconducting magnets in magnetically levitated trains</li></ol></li><li>• <b>Energy</b><ol style="list-style-type: none"><li>1. LNG for peak shaving</li><li>2. Infrared sensors for thermal loss measurements</li><li>3. Power applications of high-temperature superconductors</li></ol></li><li>• <b>Agriculture and Biology</b><ol style="list-style-type: none"><li>1. Storage of biological cells and specimens</li></ol></li></ul>
---

### 3. Types of Cryocoolers

#### 3.1. *Recuperative cryocoolers*

Cryocoolers can be classified as either recuperative or regenerative [6]. The recuperative coolers use only recuperative heat exchangers and operate with a steady flow of refrigerant through the system. The compressor operates with a fixed inlet pressure and a fixed outlet pressure. If the compressor is a reciprocating type, it must have inlet and outlet valves (valved compressor) to provide the steady flow. Scroll, screw or centrifugal compressors do not need valves to provide the steady flow. Figure 1 shows schematics of the most common recuperative cryocooler cycles. The Joule-Thomson (JT) cryocooler is very much like the vapor-compression refrigerator, except that the main heat exchanger is almost nonexistent in the vapor-compression refrigerator because the temperature span is so low. In vapor-compression refrigerators the compression takes place below the critical temperature of the refrigerant. As a result, liquefaction at room temperature occurs in the aftercooler. Expansion of the liquid in the JT capillary, orifice, or valve is relatively efficient and provides enough of a temperature drop that little or no heat exchange with the returning cold, expanded gas is required in vapor-compression refrigerators.

Most early Joule-Thomson refrigerators used a pure fluid, such as nitrogen, to reach a temperature of about 77 K, the normal boiling point for nitrogen. The compression process at room temperature takes place at a temperature

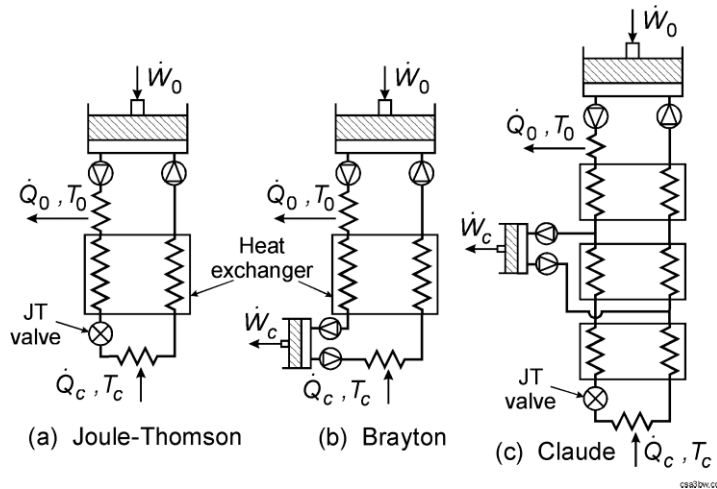

Figure 1. Schematics of recuperative cryocoolers

much above the 126 K critical temperature of nitrogen. Under these conditions the temperature drop upon expansion even from a pressure as high as 20 MPa is only about 25 K. Thus, a very efficient recuperative heat exchanger is required to reach cryogenic temperatures. More recently the pure fluids have been replaced with mixed gases, such as nitrogen, methane, ethane, and propane in the JT refrigerators to improve their performance and reduce the required pressure on the high side [3, 7, 8]. Nevertheless, the irreversible expansion of the fluid in the JT valve is less efficient than a reversible expansion with an expansion engine or turbine. Thus, the Brayton cryocooler, shown in Fig. 1b offers the potential for higher efficiency with a sacrifice in simplicity, cost, and possibly reliability. The Claude cycle combines the JT and the Brayton cycles. It is used primarily for gas liquefaction where liquid may damage the expansion engines or turbines. The use of valves in compressors and the high pressure-ratios needed for most recuperative cryocoolers limits the efficiency of the compression process to about 50% and significantly limits the overall efficiency of recuperative refrigerators.

High reliability in vapor-compression refrigerators is achieved partly because of the use of oil-lubricated compressors. Oil entrained in the refrigerant can be circulated through the cold part of the system since it does not freeze at these temperatures. However, it would freeze at cryogenic temperatures, which then necessitates that all oil be removed from the refrigerant in cryocoolers or that oil-free compressors be used. Long lifetimes are then much more difficult to achieve in cryogenic systems.

### 3.2. Regenerative Cryocoolers

The regenerative cryocoolers, as shown in Fig. 2, use at least one regenerative heat exchanger, or regenerator, and operate with oscillating flow and pressure. They are analogous to AC electrical systems, whereas the recuperative cryocoolers are analogous to DC electrical systems. In such an analogy pressure is analogous to voltage, and mass flow or volume flow is analogous to current. Further comparisons with electrical systems will be discussed later. In a regenerator incoming hot gas transfers heat to the matrix of the regenerator, where the heat is stored for a half cycle in the heat capacity of the matrix. In the second half of the cycle the returning cold gas, flowing in the opposite direction through the same channel, picks up heat from the matrix and returns the matrix to its original temperature before the cycle is repeated. At equilibrium one end of the regenerator is at room temperature while the other end is at the cold temperature. Very high surface areas for enhanced heat transfer are easily achieved in regenerators through the use of stacked fine-mesh screen or packed spheres.

#### *Stirling Refrigerator*

The Stirling cycle, as invented and patented by Robert Stirling in 1815 [9], was first used as a prime mover. In 1834 John Herschel proposed its use as a refrigerator in producing ice [10]. It was not until about 1861 that Alexander Kirk reduced the concept to practice [11]. Air was used as the working fluid in these early regenerative systems. Very little development of Stirling refrigerators occurred until 1946 when a Stirling engine at the Philips Company in Holland was run in reverse with a motor and was found to liquefy air on the cold tip [12]. The engine

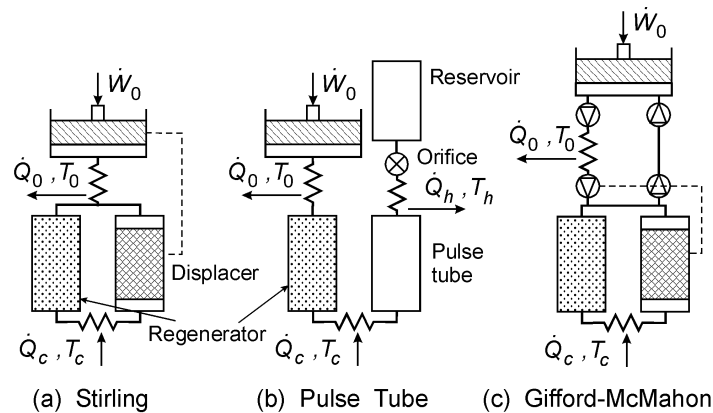

Figure 2. Schematics of regenerative cryocoolers

used helium as the working fluid, since earlier work at the company showed helium to give much improved performance to the engines. Research then began on the use of the Stirling refrigerator first as an air liquefier and about ten years later as a cryocooler for cooling infrared sensors to about 80 K. Figure 2a shows the most common form of the Stirling cryocooler used today. Because of its long history, the Stirling cryocooler may be considered the ‘parent’ of the other forms of regenerative cryocoolers shown in Fig. 2. The Gifford-McMahon and pulse tube refrigerators are variations of the Stirling refrigerator. Operation of the pulse tube refrigerator is best understood by first considering the operating principles of the Stirling refrigerator.

The compressor in the Stirling refrigerator is a valveless type; as such, it should be called a pressure oscillator, but it seldom is. It is simply an oscillating piston, or it could be an oscillating diaphragm. It creates an oscillating pressure in the system where the amplitude of oscillation is typically about 10 to 30% of the average pressure. In order to provide high power densities and keep the system small, the average pressure is typically in the range of 1 to 3 MPa (10 to 30 bar) and frequencies are in the range of 20 to 60 Hz. Helium is almost always used as the working fluid in the regenerative cycles because of its ideal gas properties, its high thermal conductivity, and its high ratio of specific heats.

A pressure oscillation by itself in a system would simply cause the temperature to oscillate and produce no refrigeration. The second moving component, the displacer, is required to separate the heating and cooling effects by introducing motion of the gas in the proper phase relationship with the pressure oscillation. When the displacer in Fig. 2a is moved downward, the helium gas is displaced to the warm end of the system through the regenerator. The piston in the compressor then compresses the gas, and the heat of compression is removed by heat exchange with the ambient. Next the displacer is moved up to displace the gas through the regenerator to the cold end of the system. The piston then expands the gas, now located at the cold end, and the cooled gas absorbs heat from the system it is cooling before the displacer forces the gas back to the warm end through the regenerator. There is little pressure difference across the displacer (only enough to overcome the pressure drop in the regenerator) but there is a large temperature difference.

In practice, motion of the piston and the displacer are almost always sinusoidal. The correct phasing occurs when the volume variation in the cold expansion space leads the volume variation in the warm compression space by about 90°. With this condition the mass flow or volume flow through the regenerator is approximately in phase with the pressure. In analogy with AC electrical systems, real power flows only with current and voltage in phase with each other. Without the displacer in the Stirling cycle the mass flow leads the pressure by 90° and no refrigeration occurs. Though the moving piston causes both compression and expansion of the gas, net power input is required to drive the system since the pressure is higher during the compression process. Likewise the moving displacer reversibly extracts net work from the gas at the cold end and transmits it to the warm end where it contributes some to the compression work. In an ideal system, with isothermal compression and expansion and a perfect regenerator, the process is reversible. Thus, the coefficient of performance *COP* for the Stirling refrigerator is the same as the Carnot *COP* given by

$$COP_{Carnot} = \frac{\dot{Q}_c}{\dot{W}_0} = \frac{T_c}{T_h - T_c}, \quad (1)$$

where  $\dot{Q}_c$  is the refrigeration power,  $\dot{W}_0$  is the power input,  $T_c$  is the cold temperature and  $T_h$  is the hot temperature. The occurrence of  $T_c$  in the denominator arises from the PV power (proportional to  $T_c$ ) recovered by the expansion process and used to help with the compression.

#### *Gifford-McMahon Refrigerator*

Because the pressure oscillates everywhere within the Stirling refrigerator, excess void volumes must be minimized to maintain a large pressure amplitude for a given swept volume of the piston. Thus, oil removal equipment cannot be tolerated, which means that the moving piston and displacer must be oil-free. But long lifetimes then become difficult to achieve. In the mid-1960s Gifford and McMahon [13] showed that the pressure oscillation for cryocoolers could be generated by the use of a rotary valve that switches between high- and low-pressure sources. The Gifford-McMahon refrigerator, shown in Fig. 2c has the same low-temperature parts as the Stirling refrigerator. The irreversible expansion through the valves significantly reduces the efficiency of the process, but the advantage of this approach is that it allows for an oil-lubricated compressor to supply the high- and low-pressure sources with oil-removal equipment on the high-pressure side. Oil-lubricated compressors were readily available at low cost from the air-conditioning industry by the mid-1960s, and they had lifetimes of at least 5 years with continuous operation. To maintain a 1 to 3 year lifetime for the PTFE-based seals on the displacer and the rotary valve, Gifford and McMahon used low speeds of 1 to 2 Hz for those two components in the cold head. The cold head could be placed quite some distance from the compressor and connected by flexible lines for the high- and low-pressure gas. These Gifford-McMahon refrigerators are now manufactured at a rate of about 20,000 per year, mostly for use in cryopumps.

#### *Pulse Tube Refrigerator*

The moving displacer in the Stirling and Gifford-McMahon refrigerators has several disadvantages. It is a source of vibration, has a short lifetime, and contributes to axial heat conduction as well as to a shuttle heat loss. In the pulse tube refrigerator, shown in Fig. 2b, the displacer is eliminated. The proper gas motion in phase with the pressure is achieved by the use of an orifice and a reservoir volume to store the gas during a half cycle. The reservoir volume is large enough that negligible pressure oscillation occurs in it during the oscillating flow. The oscillating flow through the orifice separates the heating and cooling effects just as the displacer does for the Stirling and Gifford-McMahon refrigerators. The orifice pulse tube refrigerator (OPTR) operates ideally with adiabatic compression and expansion in the pulse tube. The four steps in the cycle are as follows. (1) The piston moves down to compress the gas (helium) in the pulse tube. (2) Because this heated, compressed gas is at a higher pressure than the average in the reservoir, it flows through the orifice into the reservoir and exchanges heat with the ambient through the heat exchanger at the warm end of the pulse tube. The flow stops when the pressure in the pulse tube is reduced to the average pressure. (3) The piston moves up and expands the gas adiabatically in the pulse tube. (4) This cold, low-pressure gas in the pulse tube is forced toward the cold end by the gas flow from the reservoir into the pulse tube through the orifice. As the cold gas flows through the heat exchanger at the cold end of the pulse tube it absorbs heat from the object being cooled. The flow stops when the pressure in the pulse tube increases to the average pressure. The cycle then repeats. The function of the regenerator is the same as in the Stirling and Gifford-McMahon refrigerators in that it pre-cools the incoming high-pressure gas before it reaches the cold end.

The function of the pulse tube is to insulate the processes at its two ends. That is, it must be large enough that gas flowing from the warm end traverses only part way through the pulse tube before flow is reversed. Likewise, flow in from the cold end never reaches the warm end. Gas in the middle portion of the pulse tube never leaves the pulse tube and forms a temperature gradient that insulates the two ends. Roughly speaking, the gas in the pulse tube is divided into three segments, with the middle segment acting like a displacer but consisting of gas rather than a solid material. For this gas plug to effectively insulate the two ends of the pulse tube, turbulence in the pulse tube must be minimized. Thus, flow straightening at the two ends is crucial to the successful operation of the pulse tube refrigerator. The pulse tube is the unique component in this refrigerator that appears not to have been used previously in any other system. It could not be any simpler from a mechanical standpoint. It is simply an open tube, but the thermohydrodynamics of the processes involved in it are extremely complex and still not well understood or modeled. Its function is to transmit hydrodynamic or acoustic power in an oscillating gas system from one end to the other across a temperature gradient with a minimum of power dissipation and entropy generation.

As shown in Fig. 2b the compressor for the pulse tube refrigerator is a valveless type, sometimes referred to as a Stirling-type compressor. As mentioned previously, this is actually a pressure oscillator. The pulse tube refrigerator

can be driven with any source of oscillating pressure. It can be, and often is, driven with a valved compressor like that for the Gifford-McMahon (GM) refrigerator. In that case the refrigerator is often called a GM-type pulse tube refrigerator. Other sources of pressure oscillation will be discussed later.

#### 4. History of the Pulse Tube Refrigerator

The first pulse tube refrigerator was discovered accidentally at Syracuse University by Gifford and Longworth [14] in the mid-1960s as they were developing the Gifford McMahon refrigerator. They noticed that the closed end of a pipe became very hot when there was a pressure oscillation inside, whereas the open end toward the compressor was cool. After further studies and optimization of the geometry, they were able to achieve a low temperature of 124 K at one end when the closed end was cooled with water. In their arrangement they used a Gifford-McMahon compressor to drive the system, but there was no orifice or separate reservoir. There was a small reservoir associated with the heat exchanger at the warm end of the pulse tube. Pulse tube diameters were about 20 to 25 mm and operating frequencies were about 1 Hz. This pulse tube arrangement without an orifice is now referred to as the basic pulse tube [1].

The operating principle of the basic pulse tube refrigerator is entirely different from the orifice type discussed earlier. In the basic pulse tube refrigerator the compression and expansion process inside the pulse tube occurs about halfway between adiabatic and isothermal. Expressed more rigorously, the thermal penetration depth in the gas is comparable to the tube radius. This large boundary layer pumps heat from the cold to the hot end of the pulse tube by a shuttle action of all the gas parcels. A parcel of gas is compressed and moved toward the closed end. At the plateau of the sinusoidal motion there is time for the hot parcel of gas to transfer heat to the adjacent tube wall. Next the parcel of gas is expanded and moved away from the closed end. Near the end of its motion this cooled parcel picks up heat from the adjacent tube wall. That heat is then carried back toward the closed end as the cycle repeats. Other parcels contribute to the heat pumping action all the way from the cold to the hot end. Because heat transfer with the wall is involved, there is a critical temperature gradient where the heat pumping effect becomes zero. At that point the temperature profile of the gas during its movement exactly matches that in the tube wall. If a steeper temperature gradient were imposed on the wall, the gas would shuttle heat from the hot to the cold end. This critical temperature gradient then prevents such a system from reaching cryogenic temperatures. Efficiencies of this arrangement were very poor, and, as a result, little work was done with the basic pulse tube refrigerator after about 1970.

In the early 1980s Wheatley and coworkers [15] at Los Alamos National Laboratory began to investigate heat-pumping effects at frequencies much higher than that used in the basic pulse tube refrigerator. At frequencies of 500 to 1000 Hz resonance would occur in short tubes and lead to a standing wave. At such high frequencies the thermal penetration depth in helium is on the order of 0.1 mm. Proper heat transfer was achieved by the use of closely spaced plates inside the tube. This resonant pulse tube, better known as the thermoacoustic refrigerator [16,17] also has a low-temperature limit set by the critical temperature gradient because it, also, relies on heat transfer with the solid structure. A low temperature of about 195 K has been achieved with this type of refrigerator. Further research and development on the thermoacoustic refrigerator is continuing for use in near-ambient refrigeration and air conditioning [17].

At the Moscow Bauman Technical Institute in 1984 Mikulin *et al.* [18] introduced an orifice inside the pulse tube near the warm end and achieved a low temperature of 105 K. In 1985 Radebaugh *et al.* [1] at NIST/Boulder placed the orifice outside the pulse tube, as shown in Fig. 2c, to allow the warm heat exchanger to act as a flow straightener. The orifice was a needle valve, which allowed for an easy optimization of the flow impedance. A temperature of 60 K was then achieved. Frequencies of 5 to 10 Hz were used in those early studies and were limited by the available valveless compressor. Fundamental studies of the orifice pulse tube refrigerator were carried out at NIST over the next several years to better understand the operating principles of this device. Such studies showed that the orifice pulse tube refrigerator did not rely on heat transfer with the tube wall. In fact, such heat transfer degraded the performance. A simple harmonic model was developed to calculate the time-averaged enthalpy flow in the pulse tube and the resultant refrigeration effect [1]. The model assumed adiabatic conditions inside the pulse tube. In 1990 temperatures below 40 K were achieved at NIST and other laboratories. Still, efficiencies at 80 K were 3 to 5 times less than that of Stirling refrigerators and larger compressors were required to drive pulse tube refrigerators because of the additional void volume associated with the pulse tube component. With better understanding of the operation and further optimization of the regenerator, pulse tube and heat exchangers, efficiencies comparable to those of Stirling refrigerators at 80 K were finally achieved in 1990-1991.

## 5. Analysis of Pulse Tube Refrigerators

### 5.1. Enthalpy and Entropy Flow Model

The refrigeration power of the OPTR is derived using the First and Second Laws of Thermodynamics for an open system. Because of the oscillating flow, the expressions are simplified if averages over one cycle are made. Even though the time-averaged mass flow rate is zero, other time-averaged quantities, such as enthalpy flow, entropy flow, etc., will have nonzero values in general. We define positive flow to be in the direction from the compressor to the orifice. The First Law balance for the cold section is shown in Fig. 3. No work is extracted from the cold end, so the heat absorbed under steady state conditions at the cold end is given by

$$\dot{Q}_c = \langle \dot{H} \rangle - \langle \dot{H}_r \rangle, \quad (2)$$

where  $\langle \dot{H} \rangle$  is the time-averaged enthalpy flow in the pulse tube, and  $\langle \dot{H}_r \rangle$  is the time-averaged enthalpy flow in the regenerator, which is zero for a perfect regenerator and an ideal gas. The maximum, or gross, refrigeration power is simply the enthalpy flow in the pulse tube, with the enthalpy flow in the regenerator being considered a loss. Combining the First and Second Laws for a steady-state oscillating system gives the time-averaged enthalpy flow at any location as

$$\langle \dot{H} \rangle = \langle P_d \dot{V} \rangle + T_0 \langle \dot{S} \rangle, \quad (3)$$

where  $P_d$  is the dynamic pressure,  $\dot{V}$  is the volume flow rate,  $T_0$  is the average temperature of the gas at the location of interest, and  $\langle \dot{S} \rangle$  is the time-averaged entropy flow. The first term on the right hand side of Eq. (3) represents the potential of the gas to do reversible work in reference to the average pressure  $P_0$  if an isothermal expansion process occurred at  $T_0$  in the gas at that location. Since it is not an actual thermodynamic work term, it is sometimes referred to as the hydrodynamic work flow, hydrodynamic power, or acoustic power. Equation (3) shows that the acoustic power can be expressed as an availability or exergy flow with the reference state being  $P_0$  and  $T_0$ . The specific availability or exergy is given as  $h - T_0 s$ .

Processes within the pulse tube in the ideal case are adiabatic and reversible. In this case entropy remains constant throughout the cycle, which gives

$$\langle \dot{S} \rangle = 0 \quad (\text{ideal case}). \quad (4)$$

Equations (2) and (3) are very general and apply to any oscillating thermodynamic system, even if the flow and pressure are not sinusoidal functions of time. If they are sinusoidal, the acoustic power can be written as

$$\langle P_d \dot{V} \rangle = (1/2) P_1 \dot{V}_1 \cos \theta = (1/2) R T_0 \dot{m}_1 (P_1 / P_0) \cos \theta, \quad (5)$$

where  $P_1$  is the amplitude of the sinusoidal pressure oscillation,  $\dot{V}_1$  is the amplitude of the sinusoidal volume flow rate,  $\theta$  is the phase angle between the flow and the pressure,  $R$  is the gas constant per unit mass, and  $\dot{m}_1$  is the amplitude of the sinusoidal mass flow rate. Equations (2-4) can be combined to give the maximum or gross refrigeration power in terms of acoustic power as

$$\dot{Q}_{\max} = \langle P_d \dot{V} \rangle. \quad (6)$$

This simple expression is a very general expression and applies to the Stirling and Gifford-McMahon refrigerators as well. In those two refrigerators the acoustic work is converted to actual expansion work by the moving displacer. That work is easily measured by finding the area of the PV diagram. In the case of the pulse tube refrigerator there is no moving displacer to extract the work or to measure a PV diagram. Thus, the volume or mass flow rate must be measured by some flow meter to determine the acoustic power. Such measurements are difficult to perform inside

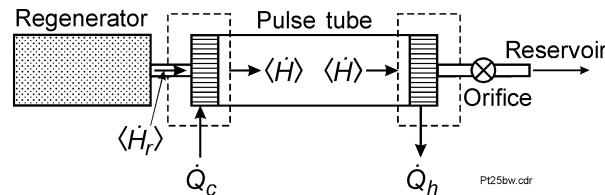

Figure 3. First law energy balance



the pulse tube without disturbing the flow and, hence, the refrigeration power. Because there is no heat exchange to the outside along a well-insulated pulse tube, the First Law shows that the time-averaged enthalpy flow through the pulse tube is constant from one end to the other. Then, according to Eq. (3) the acoustic power remains constant as long as there are no losses along the pulse tube to generate entropy. The instantaneous flow rate through the orifice is easily determined by measuring the small pressure oscillation in the reservoir and using the ideal-gas law to find the instantaneous mass flow rate. The instantaneous pressure is easily measured in the warm end of the pulse tube, and the product of it and the volume flow is integrated according to Eq. (6) to find the acoustic power. The enthalpy flow model pertaining to the ideal OPTR and leading to Eqs. (5) and (6) was discussed as early as 1986 by Radebaugh et al. [1] and refined over the next few years [19, 20, 2].

## 5.2. *Pulse Tube Losses and Effectiveness*

In an actual pulse tube refrigerator there will be losses in both the regenerator and in the pulse tube. These losses can be subtracted from the gross refrigeration power to find the net refrigeration power. The regenerator loss caused by  $\langle \dot{H}_r \rangle$  is usually the largest loss, and it can be calculated accurately only by complex numerical analysis programs, such as REGEN3.2 developed by NIST [21, 22]. The other significant loss is that associated with generation of entropy inside the pulse tube from such effects as (a) instantaneous heat transfer between the gas and the tube wall, (b) mixing of the hot and cold gas segments because of turbulence, (c) acoustic streaming or circulation of the gas within the pulse tube brought about by the oscillating pressure and gas interactions with the wall, and (d) end-effect losses associated with a transition from an adiabatic volume to an isothermal volume. The time-averaged entropy flows associated with (b), (c), and (d) are always negative, that is, flow from pulse tube to compressor. The entropy flow associated with (a) is negative at cryogenic temperatures, where the critical temperature gradient has been exceeded, but is positive at higher temperatures, where the temperature gradient is less than the critical value. Thermoacoustic models [16, 23, 24] of pulse tube refrigerators, developed between 1988 and 1995, calculate the entropy flow associated with (a), but no models have been sufficiently developed yet to calculate the entropy flows associated with (b) and (c). Because these entropy flows in the pulse tube are negative, the enthalpy flow, and, hence, the refrigeration power will be less than the acoustic power according to Eq. (3). For an ideal gas the pulse tube effectiveness is defined as [25]

$$\varepsilon = \frac{\langle \dot{H} \rangle}{\langle P_d \dot{V} \rangle}. \quad (7)$$

Measured values for  $\varepsilon$  range from about 0.55 to 0.85 in small pulse tubes [25] to as high as 0.96 in very large pulse tubes where acoustic streaming was eliminated with a slight taper [26]. These values of  $\varepsilon$  are then used as empirical factors in calculations of pulse tube performance.

## 5.3. *Effect of Phase between Flow and Pressure*

Equation (5) shows that for a given pressure amplitude and acoustic power, the mass flow amplitude is minimized for  $\theta = 0$ . Such a phase occurs at the orifice, that is, the flow is in phase with the pressure. However, because of the volume associated with the pulse tube, the flow at the cold end of the pulse tube then leads the pressure by approximately  $30^\circ$  in a correctly sized pulse tube. The gas volume in the regenerator will cause the flow at the warm end of the regenerator to lead the pressure even further, for example, by  $50$  to  $60^\circ$ . With this large phase difference the amplitude of mass flow at the warm end of the regenerator must be quite large to transmit a given acoustic power through the regenerator. This large amplitude of mass flow leads to large pressure drops as well as to poor heat exchange in the regenerator. These losses are minimized when the amplitude averaged throughout the regenerator is minimized. This occurs when the flow at the cold end lags the pressure and flow at the warm end leads the pressure. A  $30^\circ$  lag at the cold end is the approximate optimum. To achieve this phase angle requires that the flow at the warm end of the pulse tube be shifted away from its normal  $0^\circ$  phase angle to about  $-50$  to  $-60^\circ$ . In the last few years two different mechanisms have been developed to cause a beneficial phase shift between the flow and the pressure at the warm end of the pulse tube. These mechanisms, described in the following section, have led to improved efficiencies in pulse tube refrigerators.

## 6. Recent Advances

The first 5 years after the introduction of the OPTR were spent mostly in carrying out fundamental measurements to better understand the operation of the OPTR and to develop models explaining its performance. This improved understanding has led in the last ten years to improved optimizations, as well as the introduction of modifications or additional components to significantly improve the efficiency and reliability of the pulse tube refrigerator. These advances within the last ten years are described below.

### 6.1. Double Inlet Pulse Tube Refrigerator

In 1990 Zhu, Wu, and Chen [27] introduced the concept of a secondary orifice to the OPTR in which the secondary orifice allows a small fraction (about 10%) of the gas to travel directly between the compressor and the warm end of the pulse tube, thereby bypassing the regenerator. They called this the double-inlet pulse tube refrigerator. This bypass flow is used to compress and expand the portion of the gas in the warm end of the pulse tube that always remains at the warm temperature. The bypass flow reduces the flow through the regenerator, thereby reducing the regenerator loss. The flow through the secondary orifice is in phase with the pressure drop across the regenerator, which, in turn, is approximately in phase with the flow through the regenerator, averaged over its length. Since the flow usually leads the pressure, so too will the flow through the secondary. This secondary flow then forces the flow at the warm end of the pulse tube to lag the pressure, since the sum of the flows must be in phase with the pressure at the primary orifice. The location of the secondary orifice is shown in Fig. 4, along with that of an inductance tube described in the next section.

The double-inlet pulse tube refrigerator led to increased efficiencies, particularly at high frequencies where the regenerator losses would be quite high in a simple OPTR. The secondary orifice was incorporated in the mini pulse tube described by Chan *et al.* [28]. This refrigerator produced 0.5 W of cooling at 80 K with only 17 W of input power. About 30 of these mini pulse tube refrigerators have been built and are scheduled for a variety of space missions. The secondary orifice has been used on many pulse tube refrigerators built since about 1991.

### 6.2. DC Flow or Streaming

Although the introduction of the secondary orifice usually led to increased efficiencies compared to the OPTR, it also introduced a problem. Performance of the double inlet pulse tube refrigerator was not always reproducible, and sometimes the cold end temperature would slowly oscillate by several degrees with periods of several minutes or more. Researchers were attributing this erratic behavior to DC flow that can occur around the loop formed by the regenerator, pulse tube, and secondary orifice. Asymmetric flow impedance in the secondary can cause such a DC flow. DC flow carries a large enthalpy flow from the warm to the cold end even for a few percent of the AC amplitude. In 1997 Gedeon [29] showed that the acoustic power flowing from the warm to the cold end of the regenerator brings about an intrinsic driving force for DC flow or streaming in the same direction as the acoustic power flow. As a result, an asymmetric secondary is required to cancel the intrinsic tendency for this DC flow. In the author's lab the use of a needle valve for the secondary with the needle pointing toward the warm end of the pulse tube resulted in a no-load temperature on a small pulse tube refrigerator of about 35 K. When the needle valve was reversed, the no-load temperature increased to about 50 K. A tapered tube, also known as a jet pump, has also been used to cancel the DC flow [30].

Direct measurements of this small DC flow superimposed on the AC flow would be nearly impossible and have never been attempted. Instead, it is customary to measure the temperature profile on the outside of the regenerator

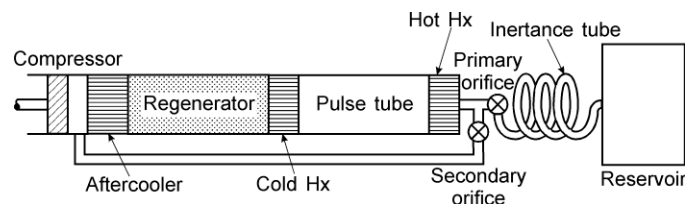

Figure 4. Schematic of the double inlet pulse tube refrigerator with inductance tube

and compare that with the calculated profile or the measured profile when the secondary is closed. Except for very low temperatures the normalized temperature at the midpoint on the regenerator is about 50 to 55% of the total temperature difference. DC flow from the warm end of the regenerator increases the midpoint temperature, whereas flow in the opposite direction reduces the midpoint temperature.

### 6.3. Acoustic Streaming

Another intrinsic streaming effect occurs within a large tube or any structure where the hydraulic radius is significantly larger than the viscous penetration depth. This is known as acoustic streaming and is driven by the oscillating flow and pressure in the viscous boundary layer. In a straight pulse tube this acoustic streaming results in the boundary layer flowing slowly from the cold to the warm end. Conservation of mass flow then requires that a flow in the opposite direction occur near the center of the pulse tube. The flow changes directions at the two ends of the pulse tube. This streaming carries with it a large enthalpy flow from the warm to the cold end of the pulse tube and reduces the effectiveness of the pulse tube as discussed earlier. This acoustic streaming can be eliminated either with the proper phase angle between flow and pressure or by the use of a tapered pulse tube [26]. So far, tapered pulse tubes have been successfully used only in rather large pulse tubes, but much further work is needed, especially in smaller systems.

### 6.4. Inertance Tubes

The conservation of momentum equation for the working fluid is

$$-\frac{\partial \mathbf{P}}{\partial x} = \frac{f_r |\dot{\mathbf{m}}| \dot{\mathbf{m}}}{2r_h \rho A_g^2} + \frac{\partial}{\partial t} \left( \frac{\dot{\mathbf{m}}}{A_g} \right) + \frac{\partial}{\partial x} \left\{ \frac{1}{\rho} \left( \frac{\dot{\mathbf{m}}}{A_g} \right)^2 \right\}, \quad (8)$$

and the conservation of mass equation is

$$\frac{\partial}{\partial x} \left( \frac{\dot{\mathbf{m}}}{A_g} \right) = -\frac{\partial \rho}{\partial t} = -\frac{\dot{\mathbf{P}}}{RT_0}, \quad (9)$$

where the bold variables represent time-varying complex variables or phasor quantities,  $x$  is the coordinate in the flow direction,  $f_r$  is the Darcy friction factor,  $r_h$  is the hydraulic radius,  $\rho_0$  is the density at the average temperature and pressure,  $A_g$  is the cross-sectional area of the gas perpendicular to the flow direction, and  $t$  is time. The ideal-gas equation of state was used for the last term in Eq. (9). Equations (8) and (9) show phase relationships between flow and pressure. The first term on the right hand side of Eq. (8) represents the flow friction or flow resistance. The last term is important only where  $A_g$  changes rapidly. The second term on the right hand side of Eq. (8) was usually neglected in the early work with OPTRs since frequencies were low (<60 Hz) and mass flow rates were low. In those cases the pressure drop was in phase with the mass flow. However, at higher frequencies or higher flow rates the second term is no longer negligible in the pulse tube or in other tubes used for the complete system. This second term gives rise to a component of the pressure drop that is in phase with the acceleration of the mass, which for a sinusoidally varying mass flow leads the flow by 90°. It represents an inertance effect and is brought about because of the inertia of the oscillating gas. It is analogous to an inductive effect in electrical systems. When combined with the resistive term, the pressure leads the mass flow by something less than 90°. As discussed earlier, this phase shifting is desirable in the pulse tube or at the warm end of it to reduce the magnitude of the flow in the regenerator.

Equation (9) shows that any element that has a finite volume causes a change in mass flow that leads the pressure by 90°, which is opposite to the desired phase shift. Such a phase shift is known as a compliance effect and is analogous to a capacitance effect in electrical systems. The overall change in phase angle from one end to the other in any element is determined by solving both Eqs. (8) and (9). The beneficial phase shift caused by an inertance effect within the pulse tube was first observed in 1996 by Godshalk et al. [31] in an OPTR operating at 350 Hz. The inertance effect can be enhanced further by using a long, narrow tube between the pulse tube and the reservoir [3,32,33], as shown in Fig. 4. The primary orifice in Fig. 4 can actually be removed and the entire flow impedance incorporated into the inertance tube. In a pulse tube providing 19 W at 90 K, Marquardt and Radebaugh [34] used an inertance tube with two diameters to provide a phase shift of 43°. The length of both tubes combined was 4.3 m,

with the small-diameter tube next to the pulse tube. In much smaller pulse tubes the phase shift is so small that it is of little use, but in much larger pulse tubes the phase shift can be larger than optimum unless the geometry of the inertance tube is adjusted to reduce the phase shift [5]. In small pulse tubes both the secondary orifice and the inertance tube need to be used together to give a desirable phase shift. The advantage of using only the inertance tube is that there is no possibility of DC flow.

### 6.5. Thermoacoustic Drivers

#### Standing Wave

In the case of the resonant pulse tube, or thermoacoustic refrigerator, as discussed earlier, there is a critical temperature gradient that cannot be exceeded with a refrigerator whenever heat transfer between the gas and the tube structure is the dominant operating mechanism. If a temperature gradient greater than the critical value is imposed on a structure of closely-spaced plates by heating one end to a high temperature ( $\approx 1000$  K) with the other end at ambient, spontaneous acoustic oscillations will occur. The resonant frequency depends primarily on the length of the tube, as in an organ pipe [16]. This standing wave device is called a ThermoAcoustic Driver (TAD). The use of a TAD to drive an OPTR is now known as a TADOPTR. The TADOPTR was first demonstrated in 1990 in a joint effort between NIST and Los Alamos National Laboratories [35]. It reached a no-load temperature of 90 K and was the first cryogenic refrigerator with no moving parts. A schematic of the TADOPTR is shown in Fig. 5. A much larger version of the TADOPTR has recently been developed to liquefy natural gas by burning a portion of the natural gas to provide the required heat source [5]. A refrigeration power of about 2 kW at 120 K has been produced by this device, which operates at a frequency of 40 Hz using a resonance tube about 12 m long. The TAD and OPTR have second-law efficiencies of about 30% and 23% of Carnot, respectively. When the system is fully optimized it is expected that about one-third of the natural gas will be burned to liquefy the remaining portion. Because the system has no moving parts, it is expected to be very reliable and of relatively low cost to manufacture.

#### Traveling Wave

In 1979 Ceperley [36] proposed another form of thermoacoustic heat engine with no moving parts, known as a traveling-wave Stirling engine. However, it was not until 1999 when this concept was reduced to practice at LANL by Backhaus and Swift [37]. The key to the successful operation of the system was the elimination of the large DC flow that normally occurs in such a structure. The system is now referred to as a ThermoAcoustic Stirling Heat Engine (TASHE). The first system assembled achieved a second-law efficiency of about 42% of Carnot. A schematic of the system is shown in Fig. 6. Instead of a stack of closely spaced plates, as used in the TAD, the

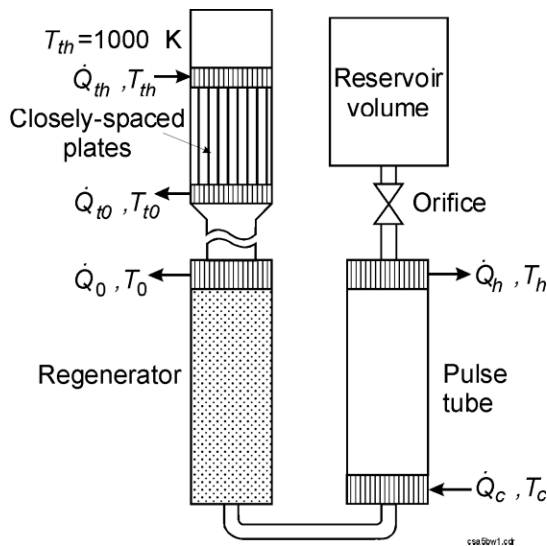

Figure 5. Schematic of ThermoAcoustically Driven Orifice Pulse Tube Refrigerator (TADOPTR) (Standing wave)

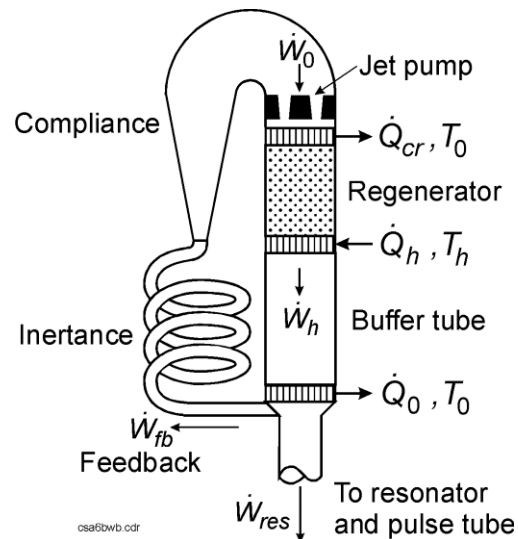

Figure 6. Schematic of ThermoAcoustic Stirling Heat Engine (TASHE) (Traveling wave)

TASHE uses a regenerator consisting of stacked stainless steel screen, just as in a cryocooler regenerator. Such a structure is easier to fabricate than a stack of closely spaced plates. In this device PV power, or acoustic power, traveling from the ambient end of the regenerator to the hot end is amplified because of the increased specific volume of the gas at the higher temperature. For an ambient temperature of 300 K and a hot end at 900 K, 1 kW of acoustic power at ambient is amplified to 3 kW at the hot end. An adiabatic compliance tube, often called a thermal buffer tube (pulse tube), allows this 3 kW acoustic power at 900 K to be transformed to 3 kW acoustic power at 300 K. Of this 3 kW, 2 kW in an ideal case can perform useful work such as driving an OPTR. The other 1 kW is fed back to the ambient end of the regenerator through a phase-shift mechanism consisting of inertance and compliance components. As with the TAD, the TASHE works best as a large system, at least for frequencies low enough (<100 Hz) for efficient operation of pulse tube refrigerators. Surface effects degrade the system performance significantly in small systems. Plans are now underway by the developers of the TADOPTR natural gas liquefier to develop a natural-gas liquefier much larger than that discussed above, but using a TASHE instead of a TAD.

### 6.6. Flexure-Bearing Compressors

The thermoacoustic drivers discussed above are useful only in large sizes, such as for industrial applications. For small systems, mechanical pressure oscillators or compressors are required to maintain high efficiency. Until recently such compressors used a dry piston rubbing inside the cylinder. Rotary drive compressors with crankshafts produce large side loads on the piston and have lifetimes of only about 1000 hours. Linear drives reduce the side loads on the piston and lead to lifetimes of about 4000 to 5000 hours. Research on improved material combinations is showing some promise in achieving lifetimes for non-lubricated compressors of up to 2 to 3 years of continuous operation.

Lifetimes of 3 to 5 years are required for most commercial applications, and lifetimes of 5 to 10 years are required for most satellite applications. At present such long lifetimes can be achieved only if all rubbing contact between the piston and the cylinder is eliminated, for example, by using flexure, gas or magnetic bearings. A flexing diaphragm can also be used in place of a piston to compress the gas. These various approaches are described in more detail by Radebaugh [3]. All of these have been tested on various Stirling refrigerators with varying success. The most common approach is the use of flexure bearings to support the piston inside the cylinder with little or no contact, as shown in Fig. 7. These flexures are flexible in the axial direction but very rigid in the radial direction. Examples of two different geometries are shown in the figure. The spiral type is the most common, and it is the type used by Davy when developing these compressors at the University of Oxford in the early 1980s [38]. These compressors are sometimes referred to as Oxford-style compressors. A clearance gap of about 10 to 20  $\mu\text{m}$  is small enough to restrict the flow through the gap in a half-cycle to much less than the volume displaced by the piston motion. During the other half-cycle the flow through the clearance gap is in the other direction since the backside of the piston is sealed to maintain the average pressure. The linear motor to drive the piston is immersed in

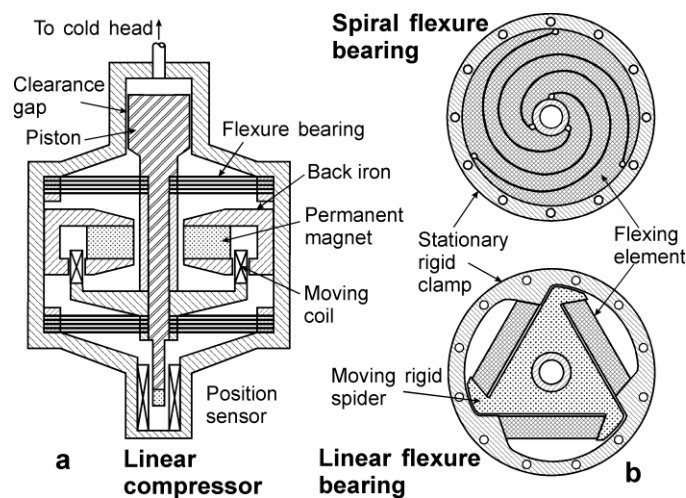

Figure 7. (a) Cross-section of a flexure-bearing linear compressor. (b) Two styles of flexure bearings

the helium gas on the backside of the piston. A linear motor using a moving coil (loudspeaker drive) in a DC field created by permanent magnets is the most common approach, although moving-magnet and moving-iron linear motors are also used in some cases. A well-designed linear compressor operating at the resonant frequency of the oscillating piston can convert electrical power to PV power at an efficiency of about 85%. In most valved compressors the conversion efficiency is only about 50%. Vibration in a linear compressor is usually eliminated by the use of dual-opposed pistons or a balancer, which can be either active or passive.

Life tests of flexure-bearing compressors have been mostly on Stirling refrigerators, for which they were originally developed. Three flexure-bearing compressors have now run at least 5 years with no failures and one has run for 10 years with no failures. When properly designed [39], the maximum stress in the flexure should be significantly less than the fatigue limit for an infinite number of cycles. Beryllium-copper or special stainless steels are normally used for the flexure bearings.

## 7. Efficiency

### 7.1. Intrinsic OPTR efficiency

In the ideal OPTR the only loss is the irreversible expansion through the orifice. The irreversible entropy generation there is a result of lost work that otherwise could have been recovered and used to help with the compression. All other components are assumed to be perfect, and the working fluid is assumed to be an ideal gas. The  $COP$  for this ideal OPTR is given by

$$COP_{ideal} = \frac{\dot{Q}_c}{\dot{W}_0} = \frac{\langle P_d \dot{V}_c \rangle}{\langle P_d \dot{V}_h \rangle} = \frac{T_c}{T_h}, \quad (10)$$

where Eq. (6) was used to relate the refrigeration power to the acoustic power at the cold end. The acoustic power at the hot end of the regenerator is simply the PV power of the compressor. Because the regenerator is assumed to be perfect, the acoustic power varies along its length in accordance with the specific volume, which is proportional to temperature for an ideal gas. The maximum  $COP$  from Eq. (10) is 1.0, but only when the cold temperature becomes equal to the hot temperature. A comparison of the  $COP$  from Eq. (10) with the Carnot  $COP$  from Eq. (1) shows that the only difference is the presence of the  $T_c$  term in the denominator of Eq. (1). That term represented the work reversibly recovered at the low temperature and used to help in the compression. The second-law efficiency of the ideal OPTR is given by

$$\eta_{ideal} = \frac{COP_{ideal}}{COP_{Carnot}} = \frac{T_h - T_c}{T_h}. \quad (11)$$

For  $T_h = 300$  K and  $T_c = 75$  K,  $\eta_{ideal} = 75\%$ . Since practical pulse tube refrigerators have efficiencies less than about 20% of Carnot, the intrinsic loss is dominated by other practical losses when operating at this low temperature. However, for  $T_c = 250$  K,  $\eta_{ideal} = 17\%$ . In that case the lost power at the orifice is a much larger fraction of the total input power. Thus, the OPTR cannot compete with the vapor-compression refrigerator for near-ambient operation. It is useful only for much lower temperatures, especially cryogenic temperatures, unless the acoustic power flow at the warm end of the pulse tube is recovered.

### 7.2. Work Recovery

An expander or displacer can be placed at the warm end of the pulse tube to recover the acoustic power in the form of real work. If that is fed back into the system to help with the compression (easily done with a displacer), the  $COP$  will be increased to the Carnot value if all else is perfect. The system is then very much like a Stirling refrigerator except that the pulse tube allows the expansion to take place at ambient temperature instead of the cold temperature. In addition, a warm expander or displacer can achieve any phase angle between the flow and the pressure to minimize the regenerator loss. A single-stage warm expander pulse tube refrigerator achieved a no-load temperature of 23.5 K in 1992 [40], the lowest temperature achieved in a single-stage pulse tube until a few years ago. The disadvantage of the warm expander is the additional moving part, although it is at ambient temperature. However, with a warm expander or displacer, no heat exchanger at the warm end of the pulse tube is required since no heat is rejected. Instead the enthalpy change at the boundary with the expander or displacer is balanced by the work recovery.

With a warm displacer, work is recovered from the pulse tube, and the same amount of work is delivered to the warm end of the regenerator in an ideal pulse tube refrigerator. No external work is required to move the displacer as long as the diameter of the drive rod is infinitely small compared to the displacer diameter. However, an external drive is needed to provide the correct phase between the displacer motion and the pressure. The reduced pressure amplitude at the cold end of a real regenerator due to viscous losses requires a small external work input to drive the displacer unless a finite diameter drive rod is used to compensate for the pressure difference on the two sides.

If the acoustic power flow toward the warm end of the pulse tube could be directed into the warm end of the regenerator, then no moving displacer or expander would be needed. Because of the pressure difference at those two locations in a real system, the proper complex impedance must be installed between the warm end of the pulse tube and the warm end of the regenerator to maintain the volume flow in the proper phase relationship with the pressure. Because of the closed loop in this system, DC flow must be canceled to prevent large losses. In 1999 Swift *et al.* [30] described a system of inductance and compliance elements to recover the acoustic power at the warm end of the pulse tube. Such a system is particularly useful for large systems or very high frequencies where inductance effects are high, and for relatively high temperatures where the acoustic power to be recovered is a significant fraction of the input power.

### 7.3. Efficiencies of Real Pulse Tube Refrigerators

Figure 8 shows a comparison of the efficiency (in terms of % of Carnot) of actual pulse tube refrigerators that have achieved high efficiencies. The efficiencies reported here refer to the input electrical power to the compressor. In a few cases the number 85 associated with a data point means that the efficiency was based on input PV power that was divided by 0.85 to obtain the electrical input power if an 85% efficient compressor had been used. The majority of pulse tube refrigerators reported in the literature have not achieved efficiencies anywhere near these values. Careful attention to details in the design of these high efficiency refrigerators is required and expensive experimental optimization is often required even after the most careful computer modeling and optimizations are performed. In most cases these detailed designs remain proprietary information. Shown for comparison are data for recent, high efficiency Stirling, Gifford-McMahon, Brayton, and mixed-refrigerant Joule-Thomson refrigerators, all operating at temperatures near 80 K. This graph shows a general trend in all refrigerators for increased efficiency as the size increases. The graph also indicates that pulse tube refrigerators have equaled or exceeded the efficiency of

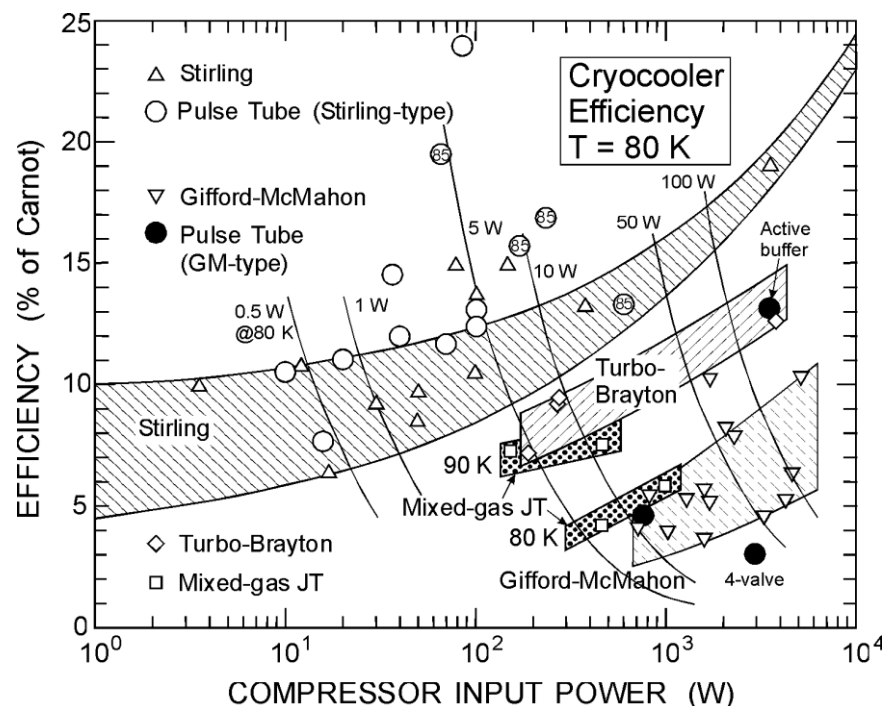

Figure 8. Efficiency of various types of cryocoolers at 80 K

the best Stirling refrigerators. As a result, pulse tube refrigerators have now become the most efficient cryocoolers for a given size, at least for temperatures between about 60 K and 120 K. Efficiencies as high as 24% of Carnot are now possible when using an 85% efficient compressor. Most of the data points referring to electrical input actually have a compressor that is about 85% efficient when a valveless compressor is used. As expected, the use of a valved compressor reduces the efficiency of the pulse tube refrigerator to about that of Gifford-McMahon refrigerators.

The earliest pulse tube refrigerator to achieve these high efficiencies was the large NIST pulse tube in 1991 that achieved 31 W at 80 K with 602 W input PV power at 316 K (13% of Carnot assuming an 85% efficient compressor). Within about a year the mini pulse tube refrigerator discussed earlier achieved about 8% of Carnot [28]. Most of the other pulse tube refrigerators with high efficiencies have been developed in the last few years for space applications with funding provided either by NASA or by the U.S. Air Force. The system with 17% efficiency at 222 W of input power is the NIST oxygen liquefier described below. It operates at 45 Hz and uses a double-diameter inertance tube for increased phase shift [34]. The most efficient pulse tube refrigerator, developed in 2001 for space applications, uses an in-line arrangement for the regenerator and pulse tube and achieved an efficiency of 24% of Carnot at 80 K[41].

## 8. Examples of Pulse Tube Refrigerators

One of the first pulse tube refrigerators developed for space applications was the miniature double-inlet system developed by Chan *et al.* [28] and discussed previously. It produces 0.5 W at 80 K with 17 W of input electrical power. It is being considered for many different space applications and about 30 have been made to date. Figure 9 shows a photograph of this refrigerator. It uses an inline arrangement of the regenerator and pulse tube, which is the most efficient because it reduces the dead volume at the cold end and minimizes turbulence from changing flow directions. Figure 10 shows a recent pulse tube refrigerator developed at NIST for NASA to be used in the laboratory to study the process of liquefying oxygen on Mars [34]. The flight program scheduled for the year 2007 would chemically convert the carbon dioxide atmosphere of Mars into oxygen, after which it is to be liquefied and stored. After about 500 days enough liquid oxygen should be collected to fire rockets for lifting off from Mars and returning to Earth with rock samples. The pulse tube liquefier shown in Fig. 10 is a coaxial geometry with the pulse tube located inside the annular regenerator. In use, the cold tip points down to eliminate gravitational-induced convection in the pulse tube. The dual-opposed compressor uses flexure bearings and moving coils. It produces 19 W of refrigeration at 90 K with 222 W of input PV power. Though this compressor is only 63% efficient, the system would have a Carnot efficiency of 17% with an 85% efficient compressor.

Recent advances in linear compressor technology at the University of Oxford have led to reduced volumes and masses for a compressor of a given PV power. A recent pulse tube refrigerator using this compressor technology and developed for NASA to cool infrared focal plane arrays to 55 K with 0.5 W of refrigeration power is shown in Fig. 11. The compressor uses 35 W of input power and has a mass of only 3.6 kg [42]. The high efficiency pulse tube cryocooler that has achieved an efficiency of 24% of Carnot at 80 K is shown in Fig. 12. It produces 7.5 W of cooling at 80 K with a power input of only 86 W. Its mass is less than 4.3 kg. The larger portion of the left half of the compressor is due to the reservoir volume mounted coaxially around the compressor.

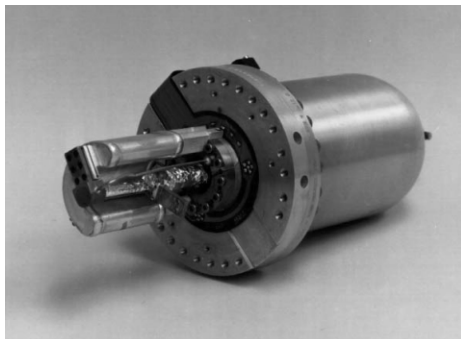

Figure 9. Mini pulse tube refrigerator for space applications (300 mm total length)

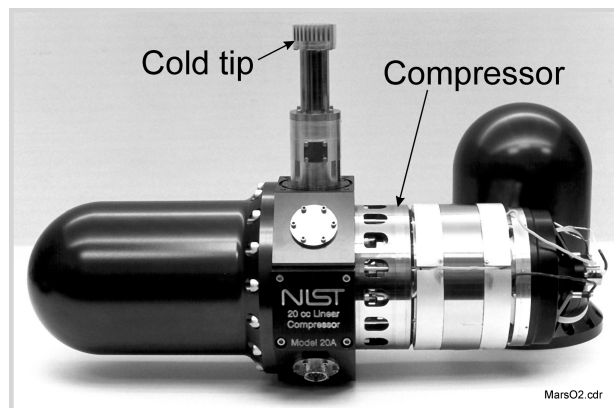

Figure 10. Pulse tube refrigerator for studies of liquefaction of oxygen on Mars (580 mm total length)



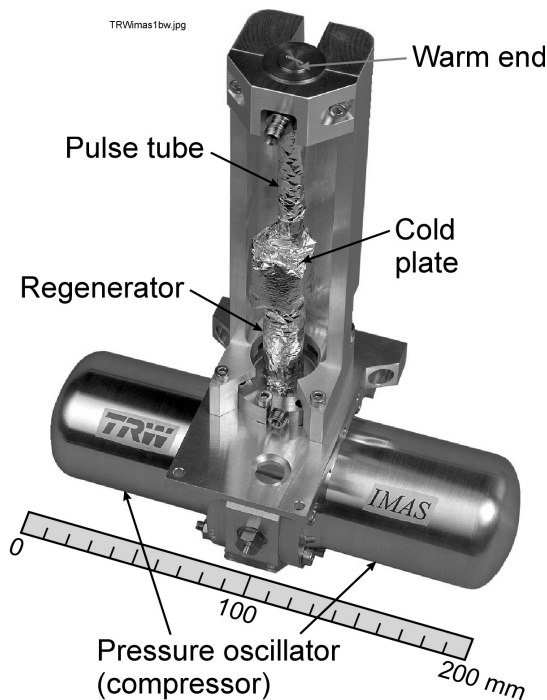

Figure 11. Pulse tube refrigerator for Integrated Multispectral Atmospheric Sounder (space appl.)

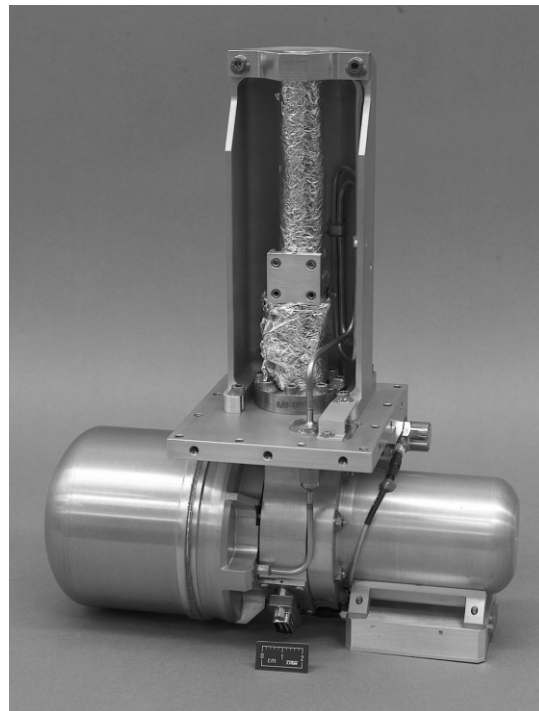

Figure 12. High efficiency pulse tube refrigerator

A very large system now under development at NIST uses a 20 kW flexure-bearing compressor to drive a two-stage pulse tube refrigerator for the liquefaction of neon at 27 K. The first stage uses a heat exchanger cooled with liquid nitrogen instead of a pulse tube for cooling at about 80 K. The goal is to provide about 500 W of cooling at 30 K. The 20 kW linear compressor is close to the maximum size that can be developed for operation at 60 Hz resonance conditions. Thermoacoustic drivers are then required for larger systems. The world's largest pulse tube refrigerator is shown in Fig. 13. It is the TADOPTR discussed earlier that burns natural gas to heat one end of the thermoacoustic driver (TAD). The pulse tube refrigerator, which uses an inertance tube, produces about 2 kW of refrigeration at 120 K and liquefies about 600 L/day of natural gas. The 12-m long resonance tube causes the system to oscillate at a frequency of 40 Hz. Even larger systems are now being designed.

In 1999 a commercial two-stage pulse tube refrigerator was described that is capable of producing 0.5 W of refrigeration at 4.2 K or liquefying helium at a rate of 4.8 L/day [43, 44]. It requires about 5.5 kW of input power to the Gifford McMahon compressor. Figure 14 shows this two-stage 4 K pulse tube refrigerator. It uses a U-tube geometry for both stages. This product followed from the earlier work in Germany and Japan on 4 K pulse tube refrigerators [4, 45]. Commercial pulse tube refrigerators are now available that provide 1.0 W of refrigeration at 4 K [46]. These pulse tube refrigerators can cool to about 2.2 K and are being used for a variety of applications, including the cooling of MRI magnets used in head imagers [47]. Vibration of the 4 K pulse tube refrigerators is over an order of magnitude less than that of Gifford-McMahon refrigerators, which allows them to be used for the head imagers [46].

## 9. Conclusions

In a time span of about 15 years the orifice pulse tube refrigerator and its variations have become the most efficient of all cryocoolers for a given size, even exceeding that of Stirling refrigerators in some cases for temperatures between about 60 and 120 K. Efficiencies of 24% of Carnot have been achieved at 80 K. They have no moving parts at the cold end, and for large systems can be driven with thermoacoustic drivers that also have no moving parts. The lack of moving parts in the cold end gives them the advantage of less vibration, higher reliability, and lower cost than all other cryocoolers, except for Joule-Thomson refrigerators, which also have no cold moving parts. However, the Joule-Thomson refrigerators currently have lower efficiencies than pulse tube refrigerators, at

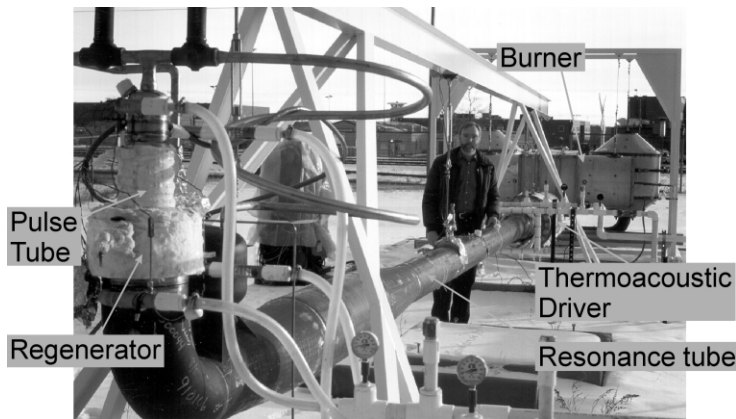

Figure 13. TADOPTR natural gas liquefier (600 L/day, 2.0 kW at 120 K)

least for temperatures below about 100 K. The use of flexure-bearing linear-resonant compressors to drive the pulse tube refrigerator results in lifetimes of at least three years and possibly even ten years or more. As a result of their high efficiency and high reliability they are being designed into many future space missions.

Commercial and industrial applications of pulse tube refrigerators are slower to develop because of the need to reduce cost while maintaining high reliability. Nevertheless, at least four companies now sell pulse tube refrigerators for commercial applications. In most cases the compressors are Gifford-McMahon type compressors, and rotary valves are used to switch between the high- and low-pressure lines. Thus, these commercial systems do not have the high efficiency of the space systems where valveless compressors are used. In a few cases Stirling-type pulse tube refrigerators are being sold commercially for high efficiency applications. So far most of the development of pulse tube refrigerators has been for rather small systems with less than a few watts of cooling at 80 K or lower. Recently there has been much more interest in pulse tube refrigerators for industrial applications in gas liquefaction and in power applications of superconductors. In many of these cases refrigeration powers of kilowatts or even tens of kilowatts are required. These are intermediate-size applications and are smaller than the large air and gas liquefaction plants where megawatts of refrigeration power are needed. At present there is not a clear upper limit to the useful size of pulse tube refrigerators.

There are three disadvantages of pulse tube refrigerators compared with some other cryocoolers. One is the sensitivity to gravitationally induced convection in the pulse tube, even during operation, whenever the pulse tube diameter is larger than about 10 mm. In the off state, convection can occur in even smaller pulse tubes. Thus, pulse tubes need to be operated with the cold end down except in zero gravity. This convection can limit some terrestrial applications where the refrigerator is to be moved about in various orientations. The second disadvantage is the extra space required for the pulse tube. Most military tactical applications for cooling infrared sensors have very well defined envelopes into which the cooler cold finger must fit. These specifications were developed many years ago when the Joule-Thomson and Stirling refrigerators were the only options. At present it is difficult to achieve the same refrigeration power in a pulse tube refrigerator with the same diameter cold finger as that of a Stirling refrigerator. The third disadvantage is that the pulse tube refrigerator is a regenerative system that utilizes oscillating pressures. Such pressure oscillations can cause the envelope of the cold finger to move due to stretching. Such vibrations are about an order of magnitude less than those generated with a moving displacer. Nevertheless, for some applications that are very vibration sensitive, even that small vibration may be too large. An example is certain space telescope applications, where turbo-Brayton cryocoolers must be used. They use steady pressures and only rotary motion.

The many advances in pulse tube refrigerators in such a short period of time have brought these refrigerators to the point where they are beginning to replace other types of cryocoolers in several applications. With further improvements, especially reduced costs, many other applications are beginning to develop, particularly in the area of

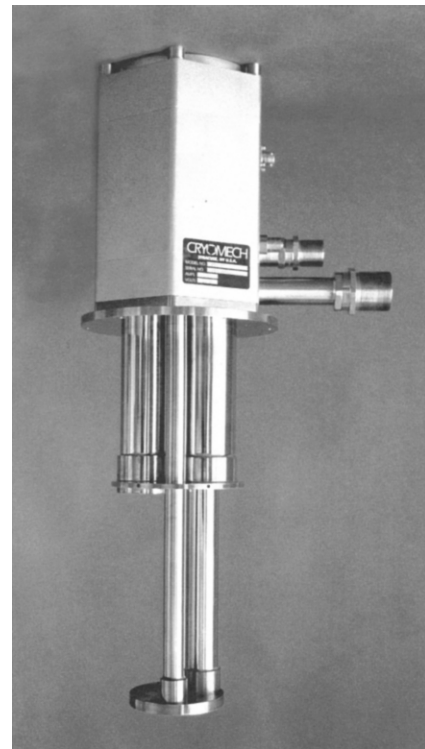

Figure 14. Cold head of commercial 4 K two-stage pulse tube refrigerator

superconductivity. Improved cryocoolers are an enabling technology for many cryogenic and superconductor applications. Pulse tube refrigerators now have the potential to be used in many of these applications.

#### REFERENCES

1. R. Radebaugh, J. Zimmerman, D. R. Smith, and B. Louie, A comparison of three types of pulse tube refrigerators: New methods for reaching 60 K, Adv. in Cryogenic Engineering, vol. 31, Plenum Press, New York (1986) pp. 779-789.
2. R. Radebaugh, A review of pulse tube refrigeration, Adv. in Cryogenic Engineering, vol. 35, Plenum Press, New York (1990) pp. 1191-1205.
3. R. Radebaugh, Advances in Cryocoolers, Proc. ICEC16/ICMC, Japan, 1966, Elsevier Science, Oxford (1997) pp. 33-44.
4. C. Wang, G. Thummes, and C. Heiden, A two-stage pulse tube cooler operating below 4 K, *Cryogenics* **37**, 159-164 (1997); Performance study on a two-stage 4 K pulse tube cooler, Adv. in Cryogenic Engineering, vol. 43, Plenum Press, NY (1998) pp. 2055-2068.
5. G. W. Swift, Thermoacoustic natural gas liquefier, Proc. of the DOE Natural Gas Conference, Houston TX, March 1997.
6. G. Walker, *Cryocoolers*, Plenum Press, New York, 1983.
7. R. C. Longworth, M. J. Boiarski, and L. A. Klusmier, 80 K closed-cycle throttle refrigerator, *Cryocoolers* **8**, Plenum Press, NY (1995) p. 537.
8. E. D. Marquardt, R. Radebaugh, J. Dobak, A cryogenic catheter for treating heart arrhythmia, Adv. in Cryogenic Engineering, vol 43, Plenum Press, New York (1998) pp. 903-910.
9. See *The Engineer* 1917; T. Finklestein, Air Engines, *The Engineer* 207, 492-497, 522-527, 568-571, 720-723 (1959).
10. J. Herschel, *The Athenaeum* (1834).
11. A. Kirk, On the Mechanical Production of Cold, Proc. Inst. Civil Eng. (London) **37**, 244-315 (1874)
12. J. W. L. Köhler and C. O. Jonkers, Fundamentals of the Gas Refrigeration Machine, Philips Tech. Rev. **16**(3), 69-78, 1954; see also, Construction of the Gas Refrigerating Machine, Philips Tech. Rev. **16**(5), 105-115, 1954.
13. H. O. McMahon and W. E. Gifford, A New Low-Temperature Gas Expansion Cycle –Part I, Adv. in Cryogenic Engineering, vol. 5, Plenum Press, New York (1960) pp.354-366.
14. W. E. Gifford and R. C. Longworth, Pulse tube refrigeration, Trans. of the ASME, Journal of Engineering for Industry, paper No. 63-WA-290, August 1964.
15. J. Wheatley, T. Hofler, G. W. Swift, and A. Migliori, Understanding some simple phenomena in thermoacoustics with applications to acoustical heat engines, *Am. J. Phys.* **53**, 147 (1985).
16. G. W. Swift, Thermoacoustic engines, *J. Acoust. Soc. Am.*, **84**, 1145-1180 (1988).
17. G. W. Swift, Thermoacoustic engines and refrigerators, *Physics Today*, pp.22-28, July 1995.
18. E. I. Mikulin, A. A. Tarasov, and M. P. Shkrebyonock, Low temperature expansion pulse tubes, Adv. in Cryogenic Engineering, vol. 29, Plenum Press, New York (1984) pp. 629-637.
19. P. J. Storch and R. Radebaugh, Development and experimental test of an analytical model of the orifice pulse tube refrigerator, Adv. in Cryogenic Engineering, vol. 33, Plenum Press, New York (1988) pp. 851-859.
20. P. J. Storch, R. Radebaugh, and J. E. Zimmerman, Analytical Model for the Refrigeration Power of the Orifice Pulse Tube Refrigerator, NIST Technical Note 1343 (1990).
21. J. Gary, D. E. Daney, and R. Radebaugh, A computational model for a regenerator, Proc. Third Cryocooler Conf., NIST Special Publication 698 (1985) pp. 199-211.
22. J. Gary and R. Radebaugh, An improved model for calculation of regenerator performance (REGEN3.1), Proc. Fourth Interagency Meeting on Cryocoolers, David Taylor Research Center Technical Report DTRC-91/003 January 1991, pp. 165-176.
23. J. H. Xiao, Thermoacoustic theory for regenerative cryocoolers: A case study for a pulse tube refrigerator, Proc. 7th Int'l Cryocooler Conf., Air Force Report PL-CP--93-1001 (1993) p. 305; Thermoacoustic heat transportation and energy transformation, Part 1: Formulation of the problem, *Cryogenics* **35**, 15 (1995); Part 2: Isothermal wall thermoacoustic effects, *Cryogenics* **35**, 21 (1995); Part 3: Adiabatic wall thermoacoustic effects, *Cryogenics* **35**, 27 (1995).
24. A. Tominaga, Basic notion of thermoacoustic theory and some results of simulations, Proc. 4th Joint Sino-Japanese Seminar on Cryocoolers and Concerned Topics, Chinese Academy of Sciences (1993) p. 79.
25. W. Rawlins, R. Radebaugh, P. E. Bradley, and K. D. Timmerhaus, Energy flows in an orifice pulse tube refrigerator, Adv. in Cryogenic Engineering, vol. 39, Plenum Press, New York (1994) pp. 1449-1456.

26. G. W. Swift, M. S. Allen, and J. J. Wollan, Performance of a tapered pulse tube, *Cryocoolers 10*, Kluwer Academic/Plenum Press, NY (1999) pp. 315-320.
27. S. Zhu, P. Wu, and Z. Chen, Double inlet pulse tube refrigerators: an important improvement, *Cryogenics* **30**, 514 (1990).
28. C. K. Chan, C. B. Jaco, J. Raab, E. Tward, and M. Waterman, Miniature pulse tube cooler, Proc.7th Int'l Cryocooler Conf., Air Force Report PL-CP--93-1001 (1993) pp. 113-124.
29. D. Gedeon, DC gas flows in Stirling and pulse tube refrigerators, *Cryocoolers 9*, Plenum Press, NY (1997) pp. 385-392.
30. G. W. Swift, D. L. Gardner, S. Backhaus, Acoustic recovery of lost power in pulse tube refrigerators, *J. Acoust. Soc. Am.* **105**, 711-724 (1999).
31. K. M. Godshalk, C. Jin, Y. K. Kwong, E. L. Hershberg, G. W. Swift, and R. Radebaugh, Characterization of 350 Hz thermoacoustically driven orifice pulse tube refrigerator with measurements of the phase of the mass flow and pressure, Adv. in Cryogenic Engineering, vol. 41, Plenum Press, NY (1996) pp. 1411-1418.
32. S. W. Zhu, S. L. Zhou, N. Yoshimura, and Y. Matsubara, Phase shift effect of the long neck tube for the pulse tube refrigerator, *Cryocoolers 9*, Plenum Press, NY, (1997) pp. 269-278.
33. D. L. Gardner and G. W. Swift, Use of inertance in orifice pulse tube refrigerators, *Cryogenics* **37**, 117-121 (1997).
34. E. D. Marquardt and R. Radebaugh, Pulse tube oxygen liquefier, Adv. in Cryogenic Engineering, vol. 45, Plenum Press, NY (2000) pp. 457-464.
35. G. W. Swift, R. A. Martin, R. Radebaugh, Acoustic Cryocooler, U.S. patent 4,953,366 (1990); R. Radebaugh, K. M. McDermott, G. W. Swift, and R. A. Martin, Development of a thermoacoustically driven orifice pulse tube refrigerator, Proc. Fourth Interagency Meeting on Cryocoolers, David Taylor Research Center Technical Report DTRC-91/003 January 1991, pp. 205-220.
36. P. H. Ceperley, A pistonless Stirling engine-the traveling wave heat engine, *J. Acoust. Soc. Am.* **66**, 1508-1513 (1979).
37. S. Backhaus and G. W. Swift, A thermoacoustic-stirling heat engine, *Nature* **399**, 335-338 (1999).
38. G. Davey, Review of the Oxford cryocooler, Adv. in Cryogenic Engineering, vol. 35, Plenum Press, New York (1990) pp. 1423-1430.
39. E. Marquardt and R. Radebaugh, Design optimization of linear-arm flexure bearings, *Cryocoolers 8*, Plenum Press, NY, (1995) pp. 293-304.
40. Y. Ishizaki and E. Ishizaki, Experimental performance of a modified pulse tube refrigerator below 80 K down to 23 K, Proc.7th Int'l Cryocooler Conf., Air Force Report PL-CP--93-1001 (1993) pp. 140-146.
41. E. Tward, C. K. Chan, J. Raab, T. Nguyen, R. Colbert, and T. Davis, High efficiency pulse tube cryocooler, *Cryocoolers 11*, Plenum Press, NY (2001) pp. 163-167.
42. C. K. Chan, T. Nguyen, R. Colbert, J. Raab, R. G. Ross, Jr., and D. L. Johnson, IMAS pulse tube cooler development and testing, *Cryocoolers 10*, Kluwer Academic/Plenum Press, NY, (1999) pp. 139-147.
43. C. Wang and P. E. Gifford, 0.5 W class two-stage 4 K pulse tube cryorefrigerator, Adv. in Cryogenic Engineering, vol. 45, Plenum Press, NY (2000) pp. 1-7.
44. C. Wang and P. E. Gifford, Performance characteristics of a 4 K pulse tube in current applications, *Cryocoolers 11*, Kluwer Academic/Plenum Press, NY, (2001) pp. 205-212.
45. Y. Matsubara and J. L. Gao, Novel configuration of three-stage pulse tube refrigerator for temperatures below 4 K, *Cryogenics* **34**, 259 (1994); Multi-stage pulse tube refrigerator for temperatures below 4 K, *Cryocoolers 8*, Plenum Press, NY (1995) p. 345-352.
46. C. Wang and P. E. Gifford, Development of 4 K pulse tube cryorefrigerators at Cryomech, Adv. in Cryogenic Engineering, vol. 47, American Institute of Physics, NY (2002) pp. 641-648.
47. P. S. Thompson, R. A. Ackermann, and R. A. Hedeon, A two-stage pulse tube cryo-cooled MRI magnet, Adv. in Cryogenic Engineering, vol. 47, American Institute of Physics, NY (2002) pp. 649-653.